

OWNER'S MANUAL
for your
Infinity SM Series
Speakers

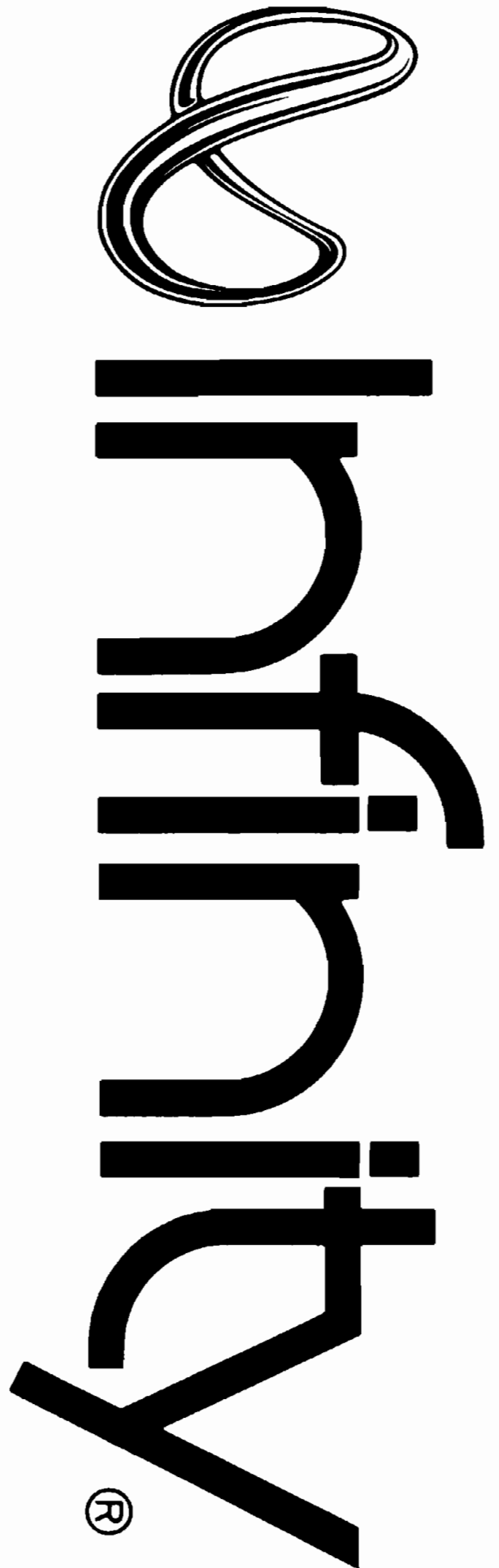

UNPACKING

Check your speaker carefully. If it has been damaged in transit, call your dealer and/or the trucking firm that delivered it.

ASSOCIATED COMPONENTS

The choice of associated components in your system is critical and should be made with great care. Here are several suggestions.

Employ a high powered amplifier. Higher power results not only in cleaner, more open sound but it insures that the speaker will not be harmed by an overdriven amplifier.

Never operate your system with the bass, treble and loudness controls set to full boost. This always places undue strain on the speaker and amplifier. The volume control settings are not a specific indication of the loudness level of the speakers. The only important consideration is the loudness level at which the system can be played regardless of where the volume control is set.

Always turn down the volume control when changing a record, or switching inputs to **AM**, or **FM** operation. Excessively loud transients (clicks or popping sounds) can damage the speakers.

Whenever changing wires, pulling plugs, etc., always turn off all equipment to prevent transients from entering the speakers. It is always worthwhile to discuss proper speaker connection and component selection with your dealer prior to setting up your system.

POSITIONING

Room acoustics vary widely and even small changes in position will affect the sound. To obtain the best results, it is worthwhile experimenting with different room positions for your speakers and listening to the results.

For the best stereo image, the speakers should be no less than 2 to 3 meters (7 to 10 feet) apart.

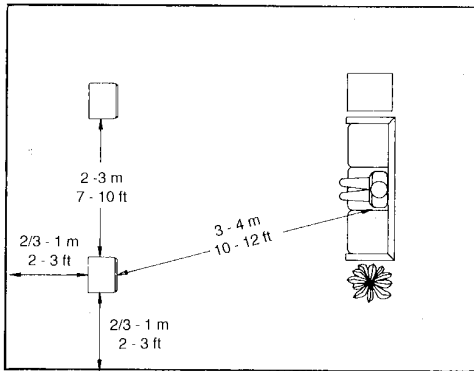

If your room is larger than average, a wider placement of the speakers may be desirable: about 4 meters (12-15 feet). Angle the speakers slightly inward toward your listening position in the room.

The proximity of your speakers to the corners and walls can affect tonal balance in the bass and lower middle frequencies.

By choice or necessity, you may be placing your **SM82** loudspeakers on a shelf directly against the wall. However, this is **not** optimum as you will sacrifice the **depth** of image that is characteristic of INFINITY speakers.

If you must mount the speakers higher than ear level, place a shim under the rear of the cabinets to angle the front plane of the speaker slightly downward.

If the speakers are mounted near the floor, a shim should be used to tilt the frontal plane of the speakers backwards, with the sound directed slightly upward.

In most homes, carpets, drapes and furniture generally balance window areas and walls, producing a relatively optimal acoustic environment.

Where extremes exist (heavy draperies, heavily carpeted floors, heavily padded furniture) overall sonic balance may be excessively dull, or dead. Wide expanses of glass, mirrored walls, glass doors, or hard surfaces on furniture may create a hard, bright sound. On some models, compensation for room acoustics can be made with the midrange and tweeter controls on your speaker, or by using the tone controls on your receiver or integrated amplifier.

CONNECTING THE SYSTEM

Make sure the amplifiers are switched off before making any connections. Connect your amplifiers to the speakers using 16 gauge (or heavier) two-conductor wire with polarity coding. It is important that the speakers be connected "in phase".

Use polarity coding to make sure that the "+" (red) terminal of each speaker is connected to its amplifier's "+" output.

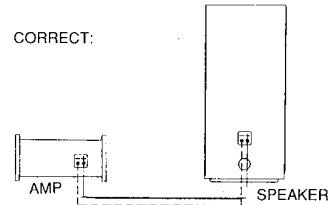

Correct ("in-phase") connection.
Plus (red) goes to plus.
Minus (black) goes to minus.

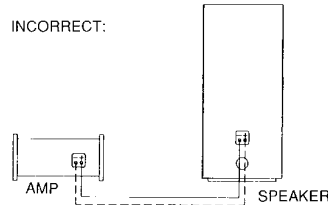

Incorrect ("out-of-phase") connection:
Plus-to-minus, minus-to-plus. Results in distorted, "out-of-phase" sound.

Before switching on, check carefully to make sure that no stray or frayed strands of wire are touching both the "+" and "-" terminals at either the speaker or the amplifier connections, as this will cause a short.

STANDS

Your speakers will perform best in a vertical position, with the bottom of the cabinets 6" to 24" above the floor. If you use a 6" stand, choose one that angles the speaker slightly backwards so that the front plane of each speaker is directed upward toward your usual listening location. A 12" stand requires less tilt to accomplish the same effect. At 18" to 24" above the floor, the speaker can be mounted parallel to the floor for optimum dispersion.

SETTING THE CONTROLS ON THE PASSIVE CROSSOVER

The **SM112** employs a tweeter level control, and the **SM122** and **SM152** employ level controls for the midrange and tweeter. These controls, located on the front of the speaker to the right of the midrange/tweeter, must be set to match room acoustics by listening to various types of program material. Generally, once set, the controls will remain at the chosen settings until the speakers are relocated.

A WORD ABOUT TONE CONTROLS

The tone controls on your electronic components (pre-amp, receiver, etc.) should be used with the utmost discretion. Excessive boost can create severe power demands on your power amplifier. Maximum bass boost can create a demand for literally hundreds of undistorted watts in the bass region, whereas, in the "flat" position, or with the tone controls switched out of the system, your average listening level may be impressively and realistically loud at less than 10 watts. The remaining power capacity required is on reserve for power peaks on sharp transients and powerful crescendos.

Your INFINITY speakers will deliver unusually even response in actual home listening environments well in excess of its conservative laboratory specifications.

NOMINAL IMPEDANCE refers to how much current is required, on the average, from an amplifier for a given voltage at its output terminals. A high impedance speaker will require less current than a low impedance speaker. Impedance is not an indication of quality or accuracy in a loudspeaker.

Solid state amplifiers, properly designed and constructed, will generally put out more power at 4 ohms. Ask your dealer about the actual power and reliability of your prospective amplifier or receiver at this impedance.

UNDERSTANDING "MIN/MAX" POWER RATINGS

If you intend to use your speakers for background music, or at moderate levels in a small room, an amplifier or receiver with less than the recommended minimum power rating can be used. But it is important to be aware of potential damage to tweeters that exists when a low-powered amplifier, or receiver is played at volumes beyond its normal limits.

At some loud "peak" listening levels, all amplifiers will "clip" off the peaks of the musical signals. When this happens, the resulting harsh distortion may contain a considerable amount of supersonic energy, which is routed to the tweeters. This high energy can destroy your tweeters.

All SM series speakers have built in self-resetting circuit breakers for the midranges and tweeters. If excessive power is applied to the speaker, a circuit breaker will temporarily interrupt the power. This may be heard as an on and off cycling of the midrange and/or tweeter. If this happens, the volume level should be reduced until the on and off cycling stops.

CARE OF YOUR SPEAKER SYSTEM

Your INFINITY speaker cabinets are finished with a heavy-duty, high quality vinyl which requires very little maintenance. Keep the cabinets clean by dusting them occasionally with a damp cloth, or use a good quality cream or spray furniture polish to maintain their original luster. (When using aerosol products, always spray the cloth, not the speaker, to help prevent any of the product from drifting onto the drivers.)

The grilles may be cleaned by gentle vacuuming.

FEEDBACK

If, after taking care in positioning your speakers, you find the bass response is boomy and lacking tightness, or you hear a rumble when playing records, or you notice excessive movement of the woofer cones, the cause may be acoustic feedback. This means that the vibrations from your speakers are reaching the turntable. Because of the exceptionally low frequency response of INFINITY speakers, isolating the turntable from these vibrations is an important consideration.

In general, make sure the turntable is placed on a heavy, solid support, as far away as possible from the speakers. If you continue to experience difficulties after some experimenting with placement, ask your INFINITY dealer for assistance.

IN CASE OF TROUBLE IN YOUR STEREO SYSTEM

Note that you can use your stereo's two channels of information for simple trouble-shooting. If the sound quality is distorted, listen to each speaker separately to check if the fault is present in both. If it is, then the trouble is likely to be elsewhere in your system. If the fault is in one channel only, reverse the outputs of your amplifier to the speakers. If the distortion moves to the other channel, the fault is not in the speaker.

If you have been unsuccessful in locating the specific sources of trouble, or if you have located it but cannot correct it, make these inquiries:

A. Consult the INFINITY dealer from whom you purchased the system.

B. Get the name and address of the authorized INFINITY service facility nearest you by writing or calling INFINITY. You may be instructed to take or

send the problem part to a service facility or the factory, for service under the terms of the warranty.

NOTE: DO NOT SHIP ANY PARTS OR WHOLE SPEAKERS FOR SERVICE WITHOUT PRIOR APPROVAL ("RETURN AUTHORIZATION"), AND DO NOT SHIP WITHOUT ENCLOSING A COPY OF YOUR ORIGINAL BILL OF SALE.

If there is no authorized service facility near you...

C. Write or phone the service department (INFINITY Customer Service, 9409 Owensmouth Avenue, Chatsworth, CA 91311; (818) 407-0228) and describe the difficulty as specifically as possible. The service department will advise you of what action you should take.

TROUBLE-SHOOTING THE SPEAKER

Before consulting your dealer, INFINITY service facility or factory service department, there are tests you can do to locate and solve possible problems in your speakers.

If a tweeter is not working:

Step 1. Remove the tweeter and check to see that the wires are connected. If they have come loose, reconnect them and put the tweeter back in place. If the connections are good but the tweeter is still not working, go on to...

Step 2. Interchange the non-working tweeter with the one from the other cabinet. If the problem follows, the tweeter is defective; call your dealer for instructions.

If a midrange is not working:

Step 1. Remove the midrange and check to see that the wires are connected. If they have come loose, reconnect them and put the midrange back in place. If the connections are good but the midrange is still not working, go on to...

Step 2. Interchange the non-working midrange with the one from the other cabinet. If the problem follows, the midrange is defective; call your dealer for instructions.

If a woofer is not working:

Step 1. Large INFINITY woofers can be quite heavy, so use caution. Lay the speaker on its back on a soft clean cloth, then remove the woofer and check to see that the wires are connected. If they have come loose, reconnect them and put the woofer back in place. If the connections are good but the woofer is still not working, go on to...

Step 2. Interchange the non-working woofer with the one from the other cabinet. If the problem follows, the woofer is defective; call your dealer for instructions.

If the sound from your speaker system still seems to be distorted, but all of the drivers seem to be operating properly, and you have ascertained that the problem is not in your stereo system's other components, the problem may lie in the passive crossover inside the affected speaker. Call your dealer for advice.

INFINITY constantly strives to update and improve existing products, as well as create new ones, therefore, the specifications and construction details in this and related INFINITY publications are subject to change without notice.